

ATEX II GD -TÜV IT 21 ATEX 001 X
 Pstat : < 500 mbar
 Pstat standard : 100 mbar +/-15% @22°C
 Max vacuum : 50 mbar pour / for Pstat 100 mbar
 Surface / Area: 1660 cm²
 Kst : dp/dt < 500 bar/s
 Kg : dp/dt < 130 bar/s
 Pmax < 12 bar / Pred. max < 1.8 bar
 - Inox 304 / stainless steel 1.4301
 - Inox 316L / stainless steel 1.4404
 - Joint / gasket EPDM Temp: -40...+80° C
 - Joint / gasket SILICONE Temp: -60..+200° C

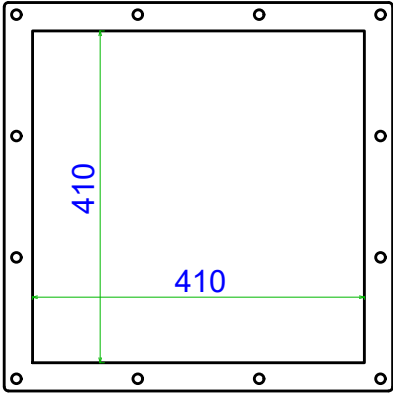

Advise bolts : M10 or 3/8"

C		07/02/25	Henry	Eric
Ind.	Objet de la modification	Date	Nom	Check
STIF SUZHOU	Material:	Poids/ Weight: 2,33 kg	Ech: s/e	
Int	Plan n°: 57VL_041_Clt	Date de creation:		
Designation:		07/02/25		
VIGILEX VL-SS 410x410		Suivi ATEX: Jim		