

ATEX II GD - TÜV IT 21 ATEX 001 X  
 Pstat : < 500 mbar  
 Pstat standard : 100 mbar +/-15% @22°C  
 Max vacuum : 50 mbar pour / for Pstat 100 mbar Surface / Area: 10360 cm<sup>2</sup>  
 Kst : dp/dt < 500 bar/s  
 Kg : dp/dt < 130 bar/s  
 Pmax < 12 bar / Pred. max < 1.8 bar  
 - Inox 304 / stainless steel 1.4301  
 - Inox 316L / stainless steel 1.4404  
 - Joint / gasket EPDM Temp: -40...+80° C  
 - Joint / gasket SILICONE Temp: -60..+200° C

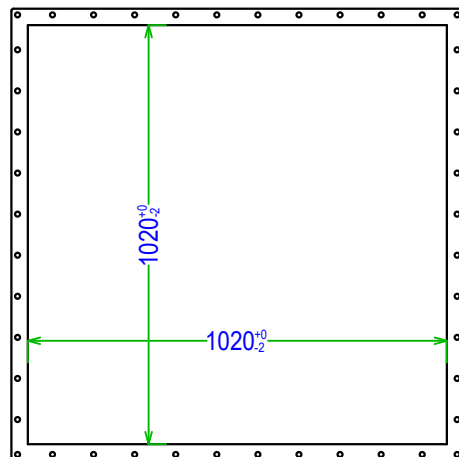

Advise bolts : M10 or 3/8"

<b>B</b>		11/07/25	Nancy	Eric
Ind.	Objet de la modification	Date	Nom	Check
<b>STIF</b> SUZHOU	Material:	Poids/Weight: 11.063kg	Ech: s/e	
<b>Int</b>	Plan n°: 57VL_102_Clt	Date de creation:		
Designation:			11/07/25	
<b>VIGILEX VL-SS 1020x1020</b>			Suivi ATEX:	
			Jim	